

(No Model.)

H. U. SEAMAN.
ENGRAVER'S VISE.

No. 420,970.

Patented Feb. 11, 1890.

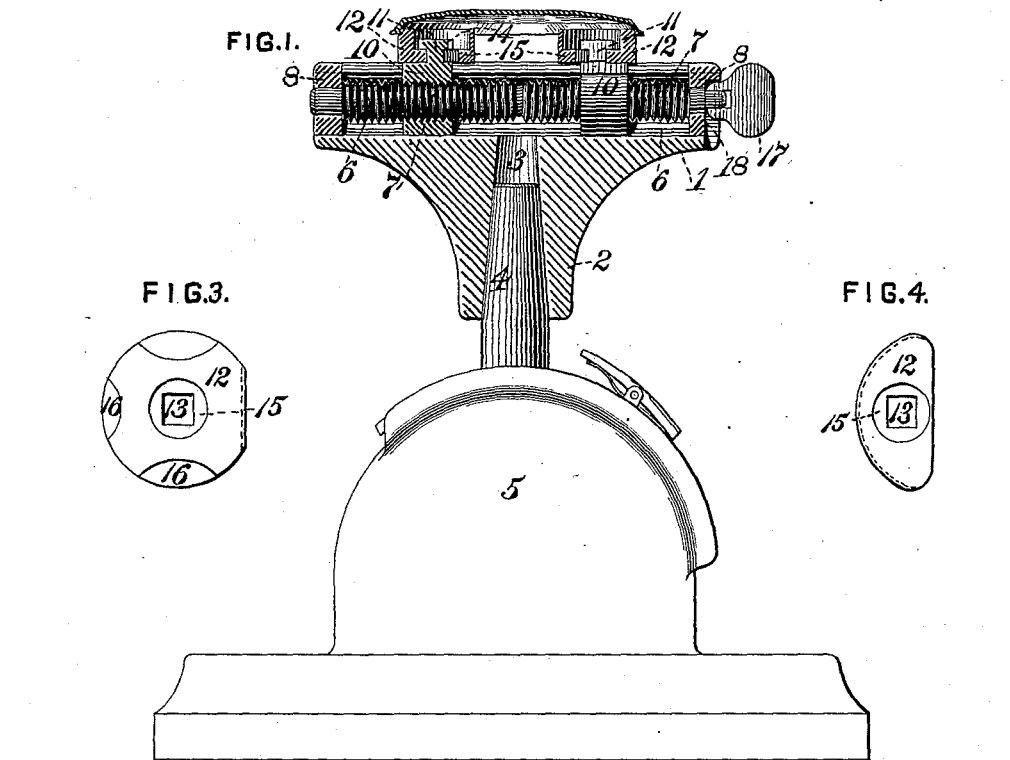
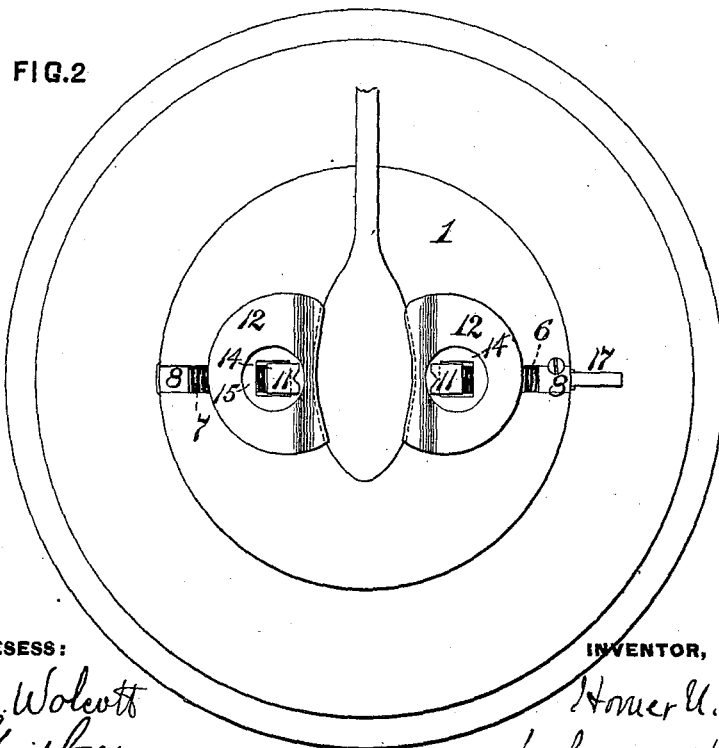

FIG. 2



WITNESSES:

Danym B. Wolcott
J. E. Gaither

INVENTOR,

Homer U. Seaman
by George H. Christy
Att'y.

UNITED STATES PATENT OFFICE.

HOMER U. SEAMAN, OF WASHINGTON, PENNSYLVANIA.

ENGRAVER'S VISE.

SPECIFICATION forming part of Letters Patent No. 420,970, dated February 11, 1890.

Application filed October 14, 1889. Serial No. 326,953. (No model.)

To all whom it may concern:

Be it known that I, HOMER U. SEAMAN, a citizen of the United States, residing at Washington, in the county of Washington and State of Pennsylvania, have invented or discovered certain new and useful Improvements in Engraver's Vises, of which improvement the following is a specification.

The invention described herein relates to certain improvements in work-holders or vises for jewelers and engravers, and has for its object such a construction of the clamping-jaws and their adjusting mechanism as will permit of their easy removal for the substitution of others, and will insure a firm engagement with the adjusting mechanism when clamping the work.

The invention claimed will be hereinafter more fully set forth.

In the accompanying drawings, forming a part of this specification, Figure 1 is a sectional elevation of the work-holder attached to an engraver's block, which is shown in elevation. Fig. 2 is a top plan view of the work-holder, and Figs. 3 and 4 are plan views of jaws adapted for different kinds of work.

Through a circular disk 1, which is provided on one side with a boss 2, having a tapering hole 3 for the reception of the spindle 4 of the block 5 or the center-pin of a lathe, is formed a diametrical slot 6, having its side walls undercut. In this slot is arranged the shaft 7, having right and left hand threads cut thereon, and journaled at its ends in the filling-pieces 8, secured in the ends of the slot, as shown. On the threaded portions of the shaft are placed correspondingly-threaded nuts or blocks 10, which are provided with stems 11, projecting a suitable distance above the face of the disk 1. These stems are preferably made rectangular in cross-section, so as to prevent any rotation of the jaws 12, which are provided with similarly-shaped openings 13, for the reception of the stems.

It has been found impracticable to prevent the jaws from gradually working off the stems or tipping, thereby releasing the article held; hence small threaded pins have been formed on the stems and the jaws held in position by nuts or by shouldered screws passing through the jaws and screwing into the blocks or threaded nuts. The removal and readjust-

ment of the nuts cause, however, considerable loss of time and annoyance through working loose and permitting the jaws to tip and release the work. In order to prevent any working off or tipping of the jaws, the stems 11 are undercut on two opposite sides, as shown, thereby forming lips 14, which will project over the portions of the jaws adjacent to openings 13, thereby preventing slipping or tipping of the jaws, as will be readily understood.

In Fig. 1 the jaws are constructed to hold a watch-case, being provided with a groove adapted to engage the inwardly-projecting ledge formed around the inner edge of the case. The case is grasped by moving the jaws outwardly, and as the movement of the jaws is arrested by the case the stems 11 will continue to move until the lips 14 overlap the jaws, as shown in Fig. 1, and thereby prevent the latter from tipping or working off the stems.

As shown in Figs. 1 and 2, the stems are provided with lips on opposite sides in order that they may engage the jaws whether moved outwardly, as described, to hold watch-cases, or inwardly to grasp spoons or other articles, as shown in Fig. 2.

In order to prevent the stems from projecting above the jaws, the latter are made of a thickness greater than the length of the stems projecting above the surface of the disk 1, and a countersink or recess is formed around the openings 13, so as to form ledges 15, with which the lips 14 may engage, as shown.

While preferring to countersink the jaws, as stated, it will be understood that the stems may be made sufficiently long with reference to the thickness of the jaws that the lips 14 will overlap the upper surfaces of the jaws.

In Fig. 3 is shown one of a pair of jaws constructed to grasp circular or rectangular disks, curved recesses 16 being formed at intervals around the jaws, which are also flattened and grooved at one point to grasp articles of irregular contour. In Figs. 1 and 4 are illustrated, as hereinbefore stated, jaws adapted to hold watch-cases, while in Fig. 2 are shown jaws constructed to hold spoons and like articles.

It will be understood that while illustrating and describing generally jaws having differ-

ently-shaped grasping portions I do not limit myself thereto, the invention herein relating more particularly to that construction of the jaws and their operating mechanism 5 whereby said parts are easily and securely connected.

On one end of the shaft 7 is pivoted a handle 17, which, when not in use, may be turned down into a recess 18, formed in the periphery 10 of the disk 1, so as to be out of the way.

While showing the vise or work-holder as mounted on an engraver's block, it will be understood that the vise may be used on a lathe or in any other suitable manner, and 15 the blocks 10 may be shifted, one or both, in any other suitable manner than that shown.

I claim herein as my invention—

1. In a vise or work-holder, the combination of blocks movable with reference to each 20 other, headed stems carried by said blocks, and jaws having openings of such size as to permit of the passage of the heads of the stems therethrough and held from vertical movement when in engagement with the article to be operated on by the heads of the 25 stems, substantially as set forth.

2. In a vise or work-holder, the combination of a right and left hand threaded shaft, blocks or nuts mounted thereon, headed stems carried by said blocks, jaws having 30 openings of such size as to permit of the passage of the heads of the stems therethrough and held from vertical movement when in engagement with the article to be operated on by the heads of the stems, substantially as 35 set forth.

3. In a vise or work-holder, the combination of blocks movable with reference to each other, headed stems carried by said blocks, and jaws having openings of such size as to 40 permit of the passage of the heads of the stems therethrough and countersunk around said openings, the ledges formed by the countersink passing under the heads of the stem, 45 substantially as set forth.

In testimony whereof I have hereunto set my hand.

HOMER U. SEAMAN.

Witnesses:

DARWIN S. WOLCOTT,
R. H. WHITTLESEY.